

FEATURES

- ✘ Compact size 3.5x6 mm
- ✘ Sharp click feeling
- ✘ Choice of SMT terminal type

APPLICATION

- ✘ Audio, OA equipment
- ✘ Instrumentation
- ✘ Industrial

SPECIFICATION

Contact Rating	50mA, 12V DC
Contact Resistance	100mΩ max.
Insulation Resistance	100MΩ min. 500V DC
Dielectric Strength	250V AC/1 minute
Operating Force	125±50gf, Black(K) 160±50gf, Brown(N) 260±50gf, Red(R) 320±80gf, Salmon(S) 520±130gf, Yellow(Y)
Travel	0.25mm
Operating Life	30,000 cycles for 520/320/260gf 50,000 cycles for 160/125gf
Operating Temp.	-25°C ~ +70°C
Storage Temp.	-30°C ~ +80°C

HOW TO ORDER

D T S □ - 3 □ □ - □ □

□: Through Hole
M: S.M.T./J-bend outward
ML: S.M.T./Flat
MF: S.M.T./Gull-wing

Package:
□=Bag(Through Hole Only)
B=Tube Package
T/R=Tape & Reel

V=RoHS & Lead Free Solderable
Q=Halogen Free

Dimension H:
1=4.3mm
2=5.0mm

Operating Force:
K=Black, 125gf
N=Brown, 160gf
R=Red, 260gf
S=Salmon, 320gf
Y=Yellow, 520gf >Not Available For Halogen Free

CIRCUIT

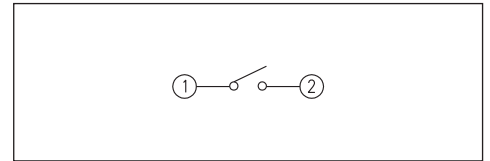

PACKAGE

- <Tube>
135 pcs
- <Bulk>
1000 pcs
- <Tape & Reel>
DTSM(L)-31: 1800 pcs
DTSM(L)-32: 1600 pcs

DTS-3

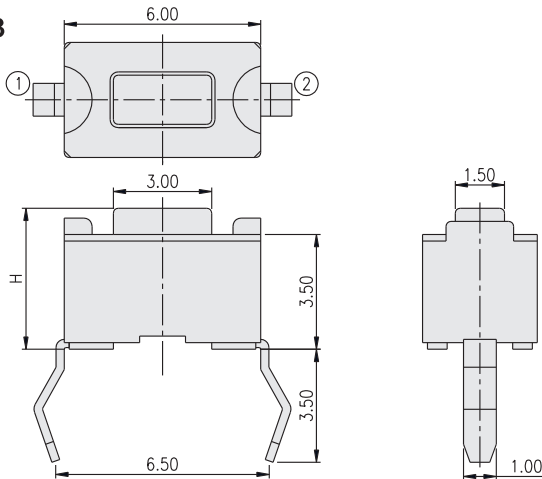

PART NO.	H
DTS-31	4.30
DTS-32	5.00

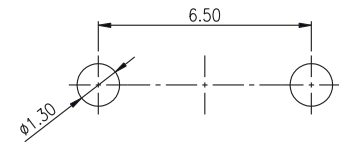

P.C.B. LAYOUT

DTSM-3

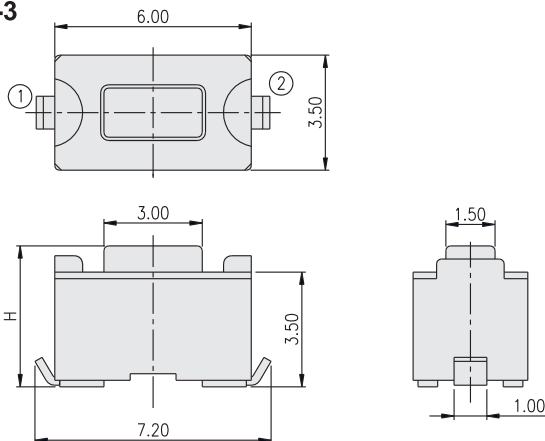

PART NO.	H
DTSM-31	4.30
DTSM-32	5.00

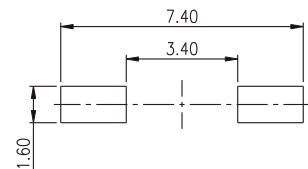

P.C.B. LAYOUT

Distributed by:

www.texim-europe.com

DTSML-3

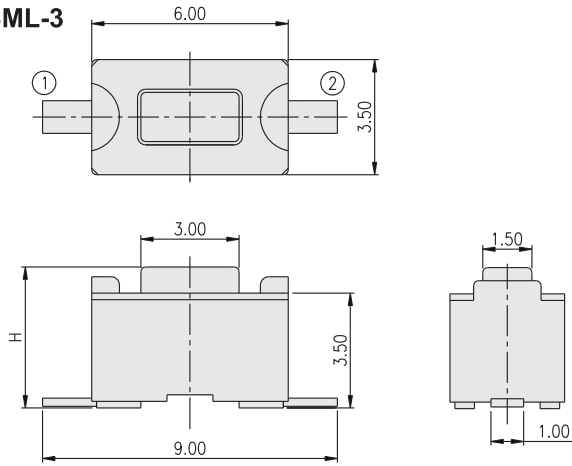

PART NO.	H
DTSML-31	4.30
DTSML-32	5.00

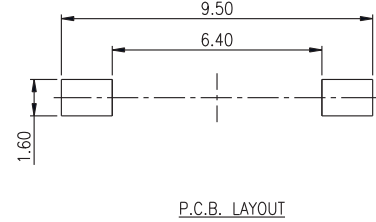

DTSMF-3

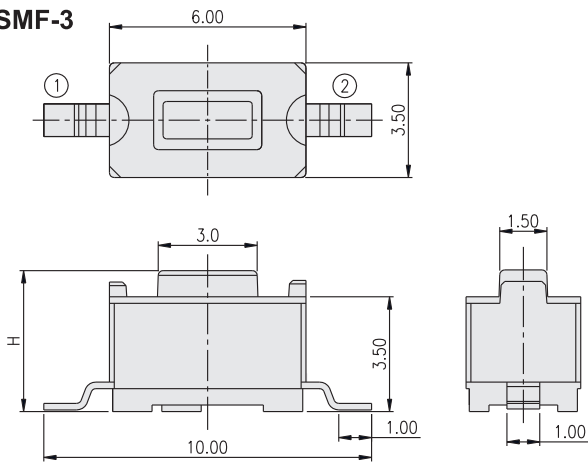

PART NO.	H
DTSMF-31	4.30
DTSMF-32	5.00

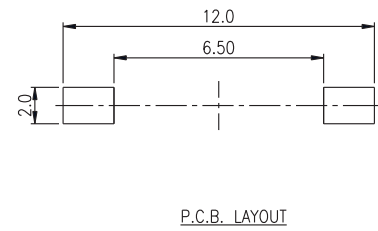

TACT SWITCH

Distributed by:

www.texim-europe.com

TEXIM EUROPE

Partner in Electronic Components & Supply Chain Solutions



The Netherlands

Elektrostraat 17
NL-7483 PG Haaksbergen
Tel: +31 (0)53 573 33 33
Fax: +31 (0)53 573 33 30
nl@texim-europe.com



Denmark

Nørregade 15
DK-9240 Nibe
Tel: +45 88 20 26 30
Fax: +45 88 20 26 39
nordic@texim-europe.com



Belgium

Gentsesteenweg 1154-C22
Chaussée de Gand 1154-C22
B-1082 Brussel / Bruxelles
Tel: +32 (0)2 462 01 00
Fax: +32 (0)2 462 01 25
belgium@texim-europe.com



United Kingdom

St. Mary's House, Church Lane
Carlton Le Moorland
Lincoln LN5 9HS
Tel: +44 (0)1522 789 555
Fax: +44 (0)845 299 22 26
uk@texim-europe.com



Germany

Justus-von-Liebig-Ring 7-9
D-25451 Quickborn
Tel: +49 (0)4106 627 07-0
Fax: +49 (0)4106 627 07-20
germany@texim-europe.com



Germany

Martin-Kollar-Strasse 9
D-81829 München
Tel: +49 (0)89 436 086-0
Fax: +49 (0)89 436 086-19
germany@texim-europe.com



Austria

Warwitzstrasse 9
A-5020 Salzburg
Tel: +43 (0)662 216026
Fax: +43 (0)662 216026-66
austria@texim-europe.com

Texim Europe B.V.

Elektrostraat 17
NL-7483 PG Haaksbergen
Tel: +31 (0)53 573 33 33
info@texim-europe.com
www.texim-europe.com

